

TYPE-DESCRIPTION

DEGASSING- AND AERATIONSYSTEM TYPE SSK FOR JERRYCANS

Technical Data:

Material: sintered oleo- and hydrophobe ultra highmolecular HDPE

Chemical Resistanze: against all hazardous liquids

GASFLOW:

Type SSK > 20 l per hour at ΔP 8 kPa

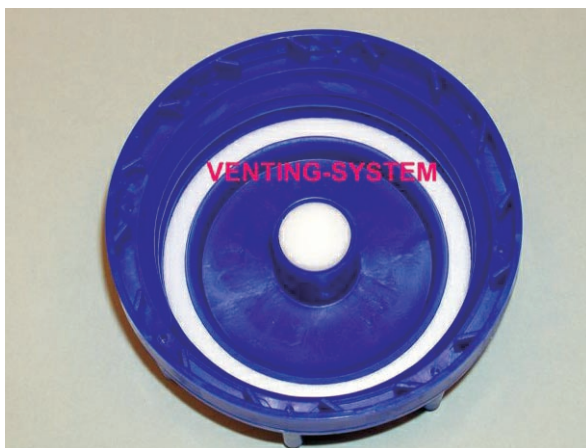

Reduction of gasflow due to contact with the filling-liquid is excluded by the OLEOPHOBIC and HYDROPHOBIC effect of the valve.

The valve can be mounted in ALL CONVENTIONAL degasification-screwcaps for jerrycans.

GASFLOW-CHART

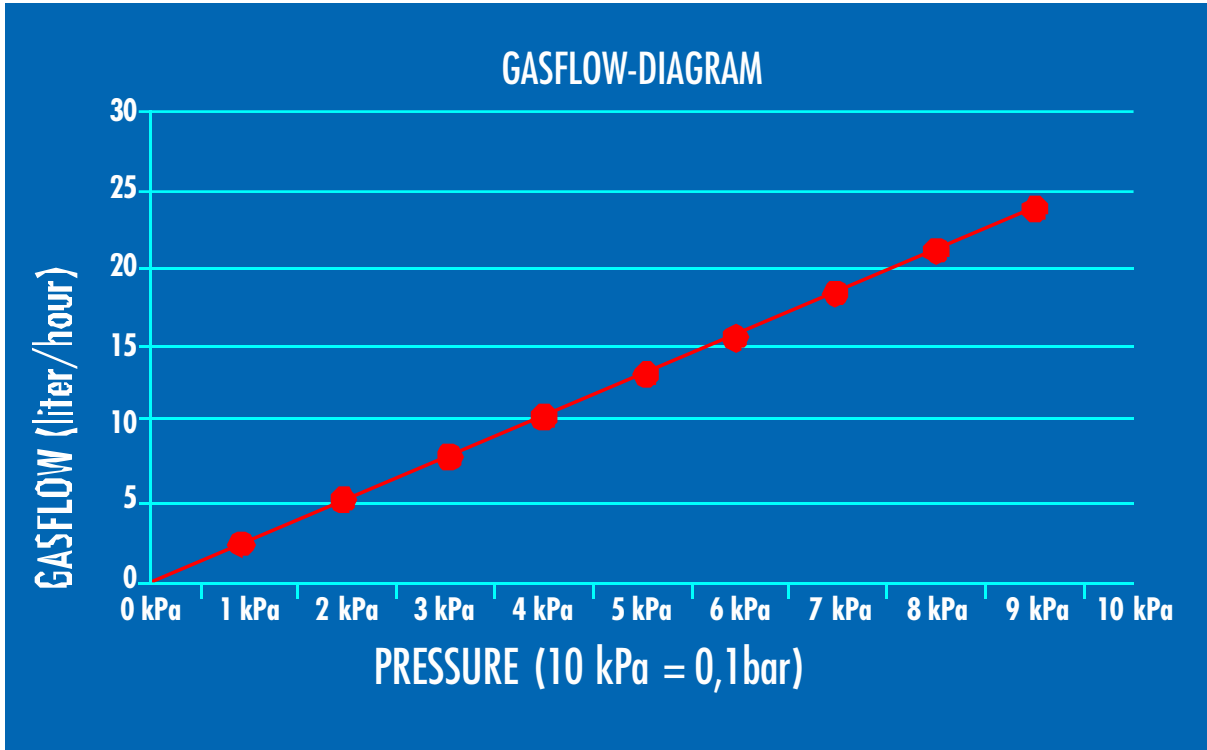

DIMENSIONS IN MM

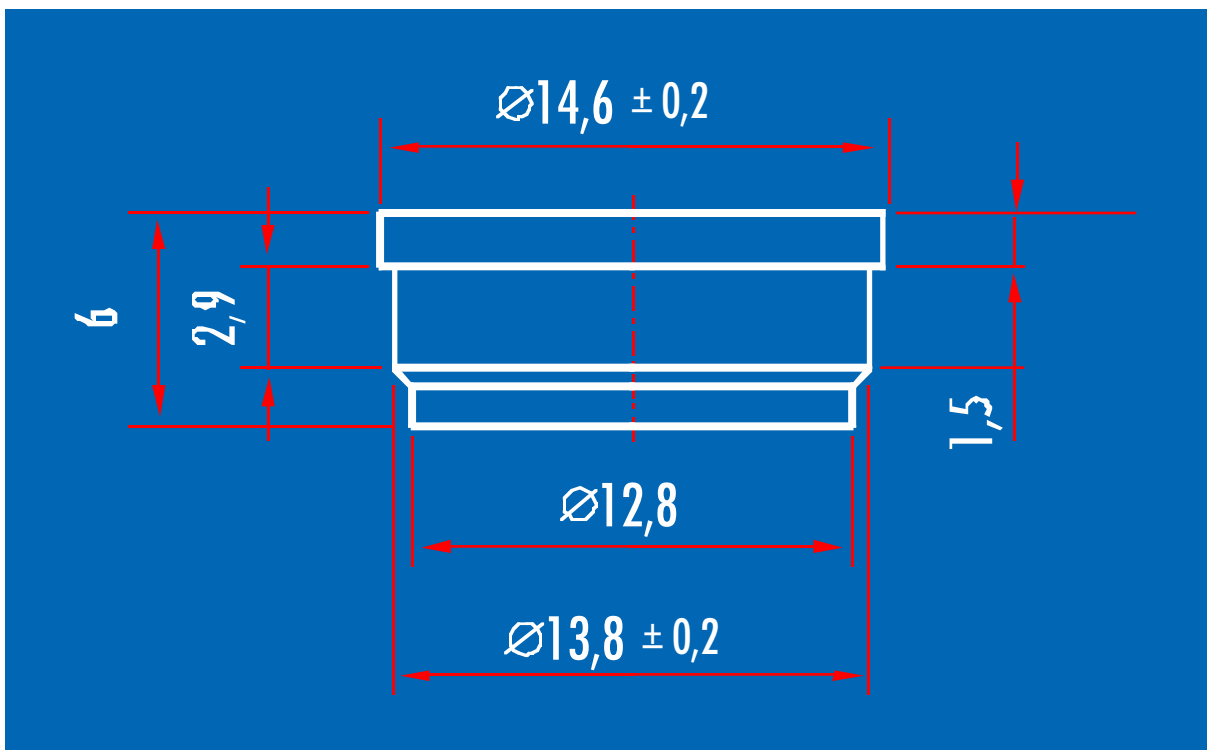

VALVE-SEAT DIMENSIONS IN MM

